

Parts List			
Pos	QTY	DESCRIPTION	MATERIAL
A	1	Outer Cage Assembly	Polycarbonate
B	1	Cage Cover	Polycarbonate
C	1	Inner Cage Assembly	PMMA
D	1	Inner Cage Bottom	PMMA

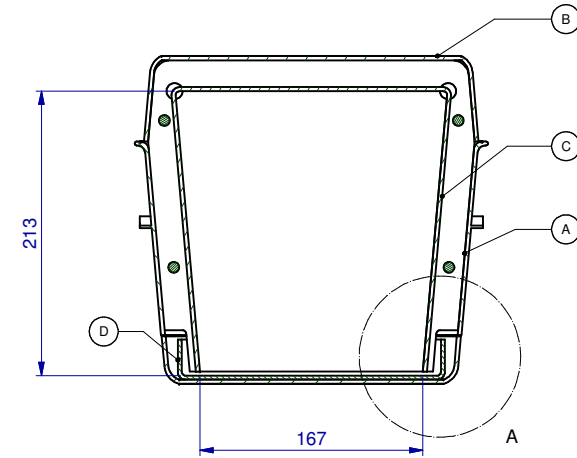

A (1:2)

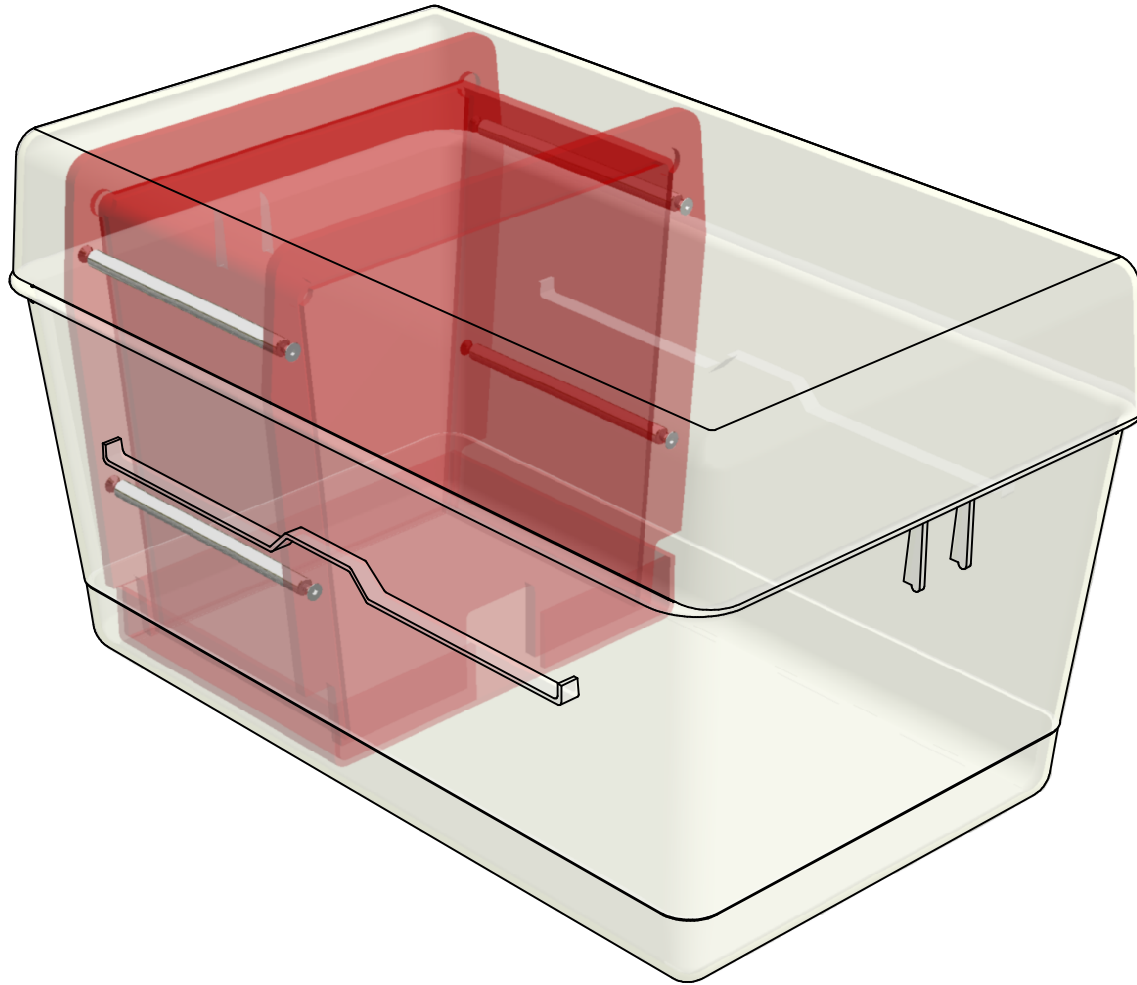
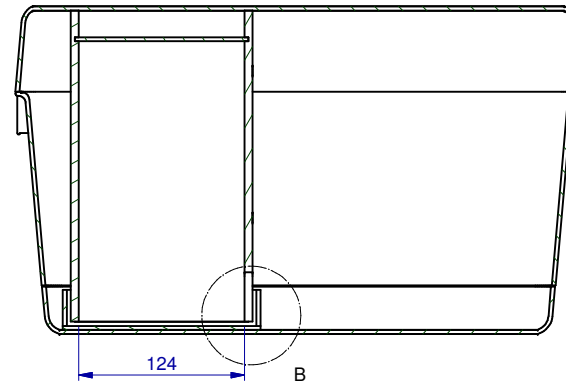
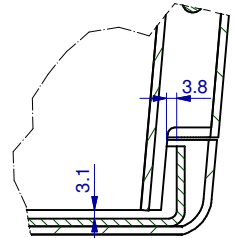

B (1:2)

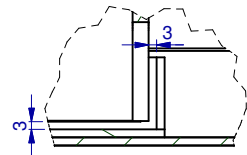

FOR INFORMATION ONLY

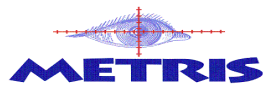
Description: Cage Assembly			Drawing No: A3003-10	
	Design:	L.T. v. Emmerik 9-2-2010	Scale: 0,45:1	
	Checked:	R. Bulthuis	Revision: A	
<small>This document remains the property of Metris BV. All rights reserved. This document or any part thereof may not be made public or disclosed, copied or otherwise reproduced or used in any form or by any means, including but not limited to the use herof for the design and manufacturing of identical or similar parts or products, without prior permission in writing from Metris BV.</small>			A3	

Parts List			
Pos	QTY	DESCRIPTION	MATERIAL
01	1	Front Plate	PMMA
02	1	Back Plate	PMMA
03	1	Middle Cover	PMMA
04	4	Column	SS
05	8	Hexagon socket countersunk head cap screw	SS
06	1	Inner Cage Bottom	PMMA

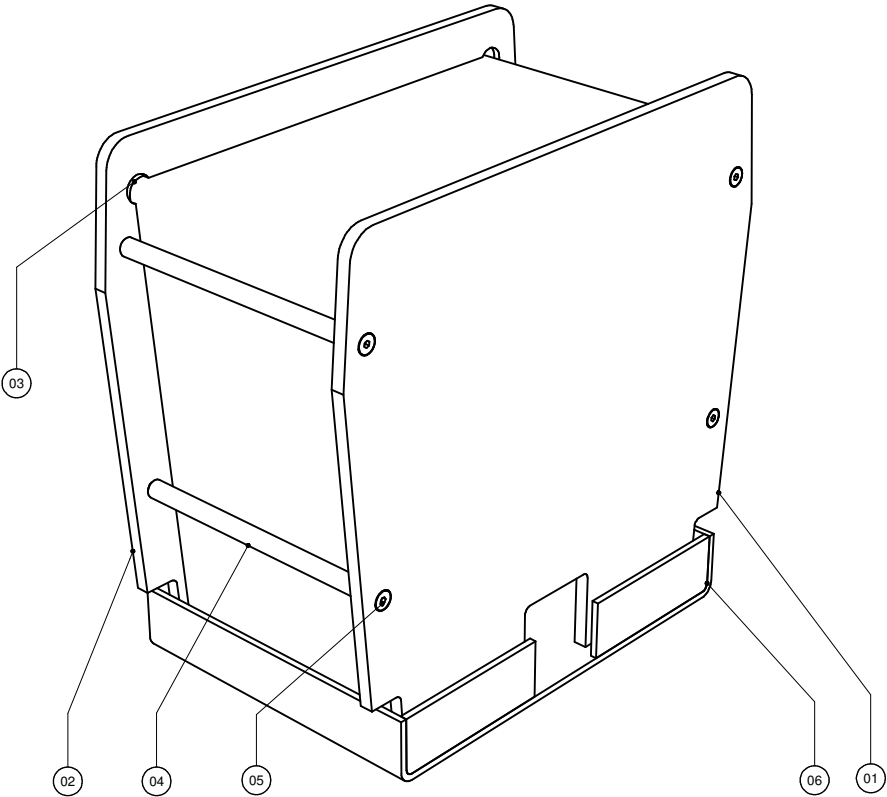

FOR INFORMATION ONLY

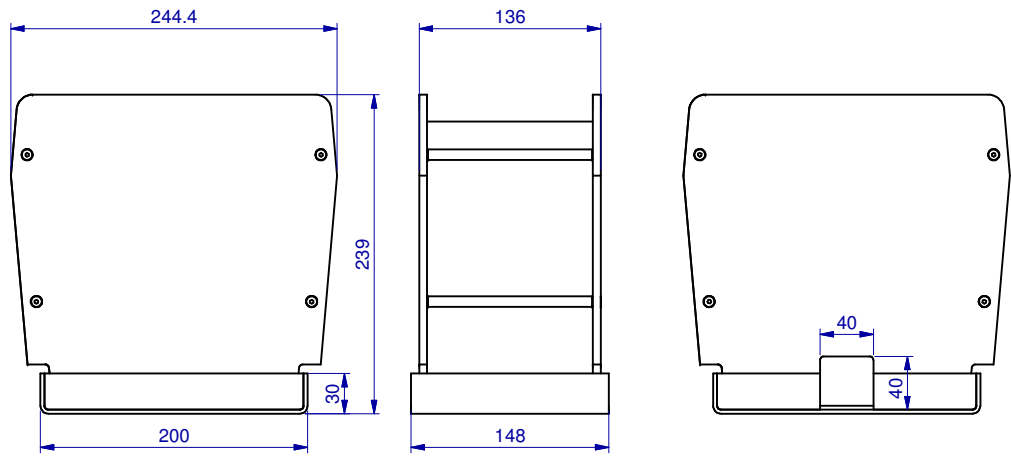
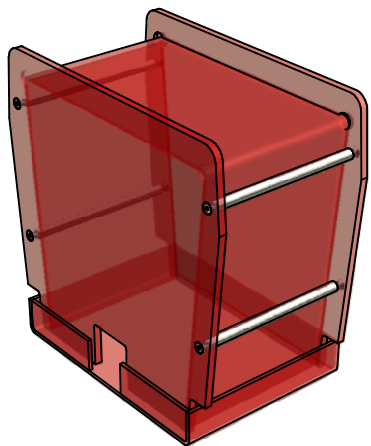

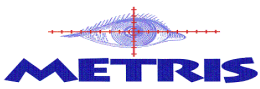
Description: Inner Cage Total Assembly			Drawing No: A3003-10	
	Design:	L.T. v. Emmerik	11-2-2010	Scale: 0,45:1
	Checked:	R. Bulthuis		Revision: A
<small>This document remains the property of Metris BV. All rights reserved. This document or any part thereof may not be made public or disclosed, copied or otherwise reproduced or used in any form or by any means, including but not limited to the use hereof for the design and manufacturing of identical or similar parts or products, without prior permission in writing from Metris BV.</small>				A3